

TECHNICAL DATA SHEET

GASIR[®] Infrared Lens

13 mm f/1.0

Umicore's GASIR[®] infrared lenses have been developed for an easy fit with a wide range of camera cores. Our catalog lenses provide a cost-effective solution for high-resolution thermal imaging and sensing applications.

This passively athermalized infrared lens is suitable for use with detectors up to 17 μm QVGA detectors. Its high reliability, quality and cost effectiveness makes it well-suited for thermal imaging applications.



OPTICAL SPECIFICATIONS

Effective focal length	12.8 mm
Radiometric f-number	f/1.0
Waveband	8 – 12 μm
Maximum field of view	25° × 18.7°
Image circle	7.0 mm

Fields of view (HFOV × VFOV)

Detector pixel pitch	Detector format	
	160 × 120	320 × 240
12 μm	8.6° × 6.4°	17.1° × 12.9°
17 μm	12.1° × 9.1°	24° × 18.2°

Other detectors may be possible. Please contact us for more information.

LENS VARIANTS

Mechanical variant	Fixed Focus 	
Mechanical interface	Standard M25	
Coating option	HEAR	DLC
Part number	11106_110	11107_110

COATING OPTIONS

	Transmission*	Lens coatings	Comments
HEAR	> 94%	HEAR on all surfaces	Maximum transmission performance.
DLC	> 87%	DLC on front surface HEAR on all other surfaces	Durable coating for unprotected exterior use. Salt fog rated.

HEAR: High Efficiency Anti-Reflection; DLC: Diamond-Like Carbon

Additional specifications are provided in the coatings Technical Data Sheets available on our website.

*average transmission over waveband



GASIR® Infrared Lens – 13 mm f/1.0

Fixed Focus

Part Number HEAR 11106_110 DLC 11107_110

Focus range	0.16 m to ∞ with 0.97 mm refocus
Operating temperature	-40 °C to +80 °C
Storage temperature	-57 °C to +105 °C
Solar radiation	MIL-STD-810G Method 505.5
Vibration	MIL-STD-810E Method 514.4 / procedure I, Cat. 8
Mechanical shock	MIL-E-5400T
Sealing	IP67
Weight	23 g
Housing material	Black anodized aluminium

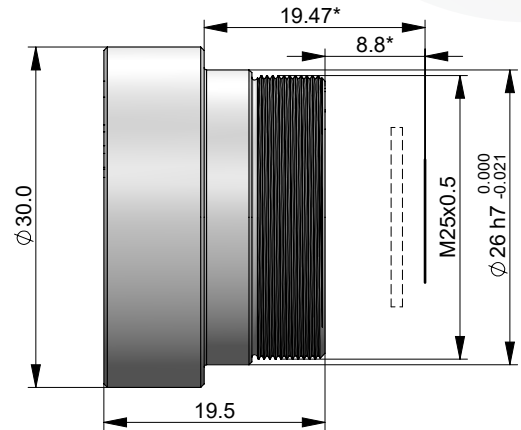

*dimensions valid with 1.0 mm Ge detector window

Electro-Optic Materials is ISO certified: ISO 9001 & ISO 14001

Umicore IR Glass
Z.A. du Boulais
35690 Acigné
FRANCE

Tel: +33 2 99 04 32 26
Fax: +33 2 99 04 32 29
optics@umicore.com

Umicore Marketing Services
No. 1800 west Zhongshan Rd
200000 Shanghai
China

Tel: +86 21 2411 6972
Fax: +86 21 2411 6988
optics.cn@umicore.com

Umicore Optical Materials Inc.
PO Box 737
Quapaw, OK 74363
USA

Tel: +1 918-673-1650
Fax: +1 918-673-2121
optics.na@umicore.com