

TECHNICAL DATA SHEET

GASIR[®] Infrared Lens

13 mm f/1.1

Umicore's GASIR[®] infrared lenses have been developed for an easy fit with a wide range of camera cores. Our catalog lenses provide a cost-effective solution for high-resolution thermal imaging and sensing applications.

This passively athermalized infrared lens is suitable for use with detectors up to 34 μm micro80 detectors. Its medium field of view makes it well-suited for thermal imaging applications.



OPTICAL SPECIFICATIONS

Effective focal length	12.8 mm
Radiometric f-number	f/1.1
Waveband	8 – 12 μm
Maximum field of view	17.8° × 13.4°
Image circle	5.0 mm

Fields of view (HFOV × VFOV)

Detector pixel pitch	Detector format		
	80 × 80	160 × 120	320 × 240
12 μm	4.3° × 4.3°	8.6° × 6.4°	17.1° × 12.9°
17 μm	6.1° × 6.1°	12.1° × 9.1°	—
34 μm	12.1° × 12.1°	—	—

Other detectors may be possible. Please contact us for more information.

LENS VARIANTS

Mechanical variant	Fixed Focus 
Mechanical interface	Standard M10
Coating option	HEAR
Part number	16084_100

COATING OPTIONS

	Transmission*	Lens coatings	Comments
HEAR	> 94%	HEAR on all surfaces	Maximum transmission performance.

HEAR: High Efficiency Anti-Reflection

Additional specifications are provided in the coatings Technical Data Sheets available on our website.

*average transmission over waveband



GASIR® Infrared Lens – 13 mm f/1.1

Fixed Focus

Part Number HEAR 16084_100

Focus range	0.06 m to ∞ with 2.59 mm refocus
Operating temperature	-10 °C to +50 °C
Storage temperature	-57 °C to +105 °C
Solar radiation	MIL-STD-810G Method 505.5
Vibration	MIL-STD-810G Method 514.6C-II / Cat. 4
Mechanical shock	MIL-E-5400T
Sealing	IP67
Weight	11 g
Housing material	Black anodized aluminium

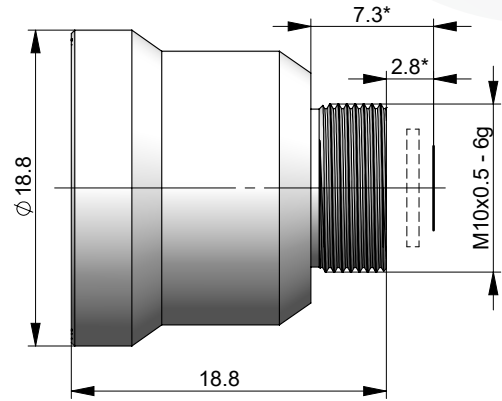

*dimensions valid with 0.725 mm Si detector window

Electro-Optic Materials is ISO certified: ISO 9001 & ISO 14001

Umicore IR Glass
Z.A. du Boulais
35690 Acigné
FRANCE

Tel: +33 2 99 04 32 26
Fax: +33 2 99 04 32 29
optics@umicore.com

Umicore Marketing Services
No. 1800 west Zhongshan Rd
200000 Shanghai
China

Tel: +86 21 2411 6972
Fax: +86 21 2411 6988
optics.cn@umicore.com

Umicore Optical Materials Inc.
PO Box 737
Quapaw, OK 74363
USA

Tel: +1 918-673-1650
Fax: +1 918-673-2121
optics.na@umicore.com